

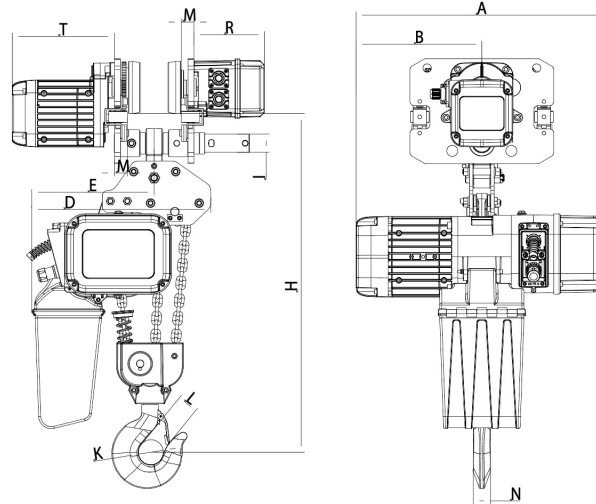

**3 ton Electric Chain Hoist w/ Power
Trolley 2 Speed 575V 3 ϕ 1/2 50/60HZ**

Especificaciones Técnicas

Capacidad de Carga	3 ton	Plug	Open Leads
Altura de Izaje Estandar (Customizable)	30 ft / 9 m	Velocidad /min	1 st speed : (11.1 ft @60Hz - 1.7 mt @50Hz) / 2 nd speed : (21.2 ft @60Hz - 5.4 mt @50Hz)
Numero de Velocidades	2 Speed	Voltaje	3 Phase 575v 50/60 Hz
Clase de Servicio	H4/M5/2m/Class D	Protección IEC Motor	IP55
Control	Pendant Control IP66	Voltaje del Control	24V
Tipo Transmisión / Reductor	Spur gearbox	Tipo de Cadena	G100 Nickel
Dimensiones de la Cadena	11.2 mm	Caidas de Cadena	1
Longitud de cadena	30	Humedad	20%~90%
Temperatura	-4 ~ 104° F / -20 ~ 40° C	Potencia del Trolley	500
Velocidad del Trolley /min	14.17~43.30 ft @60Hz 3.6~11 mt @50Hz	Cantidad de Velocidades	2
Rango de ancho de la Viga	3.9" to 7"	Radio Minimo de Giro	1.6
Normas	ASME HST-1 , ASME B30.16 , B30.17 , EN60204-35	Garantía	3 Year
Hoist Contactors Amps	25A	Hoist Contactor Brand	Schneider
Hoist Contactor Model	LC1D25B7C / LC1D25B87C	Hoist Contactor Coil Voltage	24 V
IEC Hoist IP Protection	IP55	Pendant Control Yes No	Yes
IEC Pendant Control Protection	IP66	Pendant Control Emergency Stop	Yes
Pendant Control total Length	27 ft	Hoist Motor Power in KW	3
Hoist Motor Brake Type and DC Voltage	DC260V	Overload Protection	Overload Motor Clutch
Hour Meter	Internal Working Hour Meter	Brake rectifiers-half-wave	PWRX-BKTF-HW
Hoist Motor Insulation Grade	F	Recommended Hoist Protection Circuit Breaker AMPs and Type	Type D 5A at 575V
Optional Load Chain Brand & Country of Origin	FEC Japan	Reducer Lubrication Type	Oil
Paint Specifications	Electrostatic Sprayed Plastic (ESP) Epoxy resins, Polyester Resins, Barium, Pigments	Trolley Motor Brake Type and DC Voltage	DC260V
Trolley Motor Insulation Grade	F	Trolley Contactors Amps	32A
Trolley Contactors Brand	Schneider	Trolley Contactors Model	LC1D12B7C / LC1D12B87C
Trolley Contactors Coil Voltage	24 V	Trolley Wheel Diameter	124
Trolley Wheel Material	No. 45 steel	Trolley Minimum Turn Radius	1.6 m / 5.2 ft
Trolley Beam Range	3.9" to 7"	Trolley Beam Extension Kit	up to 12"
Load Chain weight per foot [lbs]	1.83	1st Package Type	Wood Crate
2nd Package Type	Wood Crate		



H	A	B	D	E	I	M	N	K	L	T	R
645	590	276	425	290	43	30	34	59	48	242	.167

Peso & Dimensiones

Peso Total 451 lbs / 205 Kg

Detalles del Empaque

H Altura Muerta 25.39

A Altura Total 25.39

D Depth 26.81

W Ancho 13.78

J Boca Gancho 2.32

Peso Total (sin cable o cadena) 268.23

Referential Images / Imágenes Referenciales
Specifications may change without notice / las especificaciones pueden cambiar sin previo aviso