

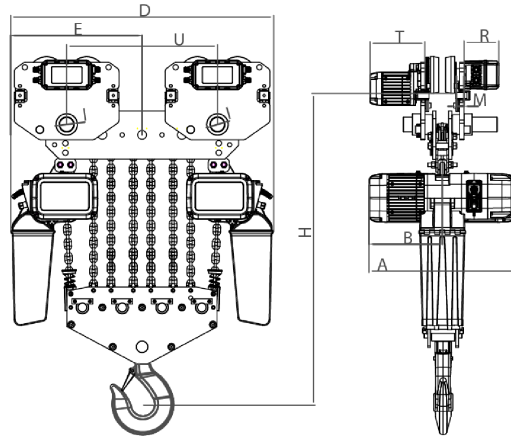

**20 ton Electric Chain Hoist w/  
Power Trolley Variable Speed  
Trolley 380V 3 $\phi$ , 50HZ 40ft G100  
Nickel Duty H4/M5**

## Especificaciones Técnicas

<b>Plug</b>	Open Leads	<b>Capacidad de Carga</b>	20 ton
<b>Altura de Izaje Estandar (Customizable)</b>	40 ft / 12 m	<b>Velocidad /min</b>	5.31 ft @60Hz 1.35 mt @50Hz
<b>Numero de Velocidades</b>	1 Speed	<b>Voltaje</b>	3 Phase 380V 50Hz
<b>Clase de Servicio</b>	H4/M5/2m/Class D	<b>Protección IEC Motor</b>	IP55
<b>Control</b>	Pendant Control IP66	<b>Voltaje del Control</b>	24V
<b>Tipo Transmisión / Reductor</b>	Spur gearbox	<b>Tipo de Cadena</b>	G100 Nickel
<b>Dimensiones de la Cadena</b>	11.2 mm	<b>Caidas de Cadena</b>	8
<b>Longitud de cadena</b>	320	<b>Humedad</b>	20%~90%
<b>Temperatura</b>	-4 ~ 104° F / -20 ~ 40° C	<b>Potencia del Trolley</b>	750+750
<b>Velocidad del Trolley /min</b>	2.75~27.55 ft @60Hz 0.7~7 mt @50Hz	<b>Cantidad de Velocidades</b>	Variable
<b>Normas</b>	ASME HST-1 , ASME B30.16 , B30.17 , EN60204-39	<b>Garantía</b>	3 Year
<b>Hoist Contactors Amps</b>	25A	<b>Hoist Contactor Brand</b>	Schneider
<b>Hoist Contactor Model</b>	LC1D25B7C	<b>Hoist Contactor Coil Voltage</b>	24 V
<b>IEC Hoist IP Protection</b>	IP55	<b>Pendant Control Yes No</b>	Yes
<b>IEC Pendant Control Protection</b>	IP66	<b>Pendant Control Emergency Stop</b>	Yes
<b>Pendant Control total Length</b>	37 ft	<b>Hoist Motor Power in KW</b>	3+3
<b>Hoist Motor Brake Type and DC Voltage</b>	DC170V	<b>Overload Protection</b>	Overload Motor Clutch
<b>Hour Meter</b>	Internal Working Hour Meter	<b>Brake rectifiers-half-wave</b>	PWRX-BKTF-HW
<b>Hoist Motor Insulation Grade</b>	F	<b>Recommended Hoist Protection Circuit Breaker AMPs and Type</b>	Type D 30A
<b>Optional Load Chain Brand &amp; Country of Origin</b>	FEC Japan	<b>Reducer Lubrication Type</b>	Oil
<b>Paint Specifications</b>	Electrostatic Sprayed Plastic (ESP) Epoxy resins, Polyester Resins, Barium, Pigments	<b>Trolley Motor Brake Type and DC Voltage</b>	DC170V
<b>Trolley Motor Insulation Grade</b>	F	<b>Trolley VFD Power in KW</b>	2.5kW
<b>Trolley VFD Brand</b>	Huayuan	<b>Trolley VFD Model</b>	Z231
<b>Trolley Wheel Diameter</b>	139	<b>Trolley Wheel Material</b>	No. 45 steel
<b>Trolley Minimum Turn Radius</b>	2.2 m / 7.2 ft	<b>Trolley Beam Range</b>	5.9" to 8.6"
<b>Trolley Beam Extension Kit</b>	up to 12"	<b>Load Chain weight per foot [lbs]</b>	1.83
<b>1st Package Type</b>	Wood Crate	<b>2nd Package Type</b>	Wood Crate



Rated load (t)	Type	Dimension (mm)												
		Minimum distance from the bottom of the track to the bottom hook: H	A	L	B	D	E	I	M	N	K	L	T	R
20	PWRXT20-08	1300	700	3500-5500	350	1246	623	71	40	80	120	96	242	167

## Peso & Dimensiones

**Peso Total** 1848 lbs / 839 Kg

## Detalles del Empaque

**H Altura Muerta** 48.82

**A Altura Total** 51.18

**D Depth** 27.56

**W Ancho** 49.06

**J Boca Gancho** 4.72

**Peso Total (sin cable o cadena)** 845.76

Referential Images / Imágenes Referenciales  
Specifications may change without notice / las especificaciones pueden cambiar sin previo aviso