

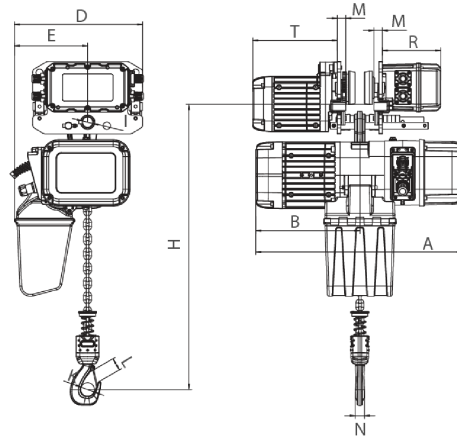

**2 ton Electric Chain Hoist w/ Power
Trolley 1 Speed 380V 3ø 50HZ**

Especificaciones Técnicas

Plug	Open Leads	Capacidad de Carga	2 ton
Altura de Izaje Estandard (Customizable)	20 ft / 6 m	Velocidad /min	26.77 ft @60Hz 6.80 mt @50Hz
Numero de Velocidades	1 Speed	Voltaje	3 Phase 380V 50Hz
Clase de Servicio	H4/M5/2m/Class D	Protección IEC Motor	IP55
Control	Pendant Control IP66	Voltaje del Control	24V
Tipo Transmisión / Reductor	Spur gearbox	Tipo de Cadena	G100 Nickel
Dimensiones de la Cadena	10 mm	Caidas de Cadena	1
Longitud de cadena	20	Humedad	20%~90%
Temperatura	-4 ~ 104° F / -20 ~ 40° C	Potencia del Trolley	500
Velocidad del Trolley /min	43.30 ft @60Hz 11 mt @50Hz	Cantidad de Velocidades	1
Normas	ASME HST-1 , ASME B30.16 , B30.17 , EN60204-34	Garantía	3 Year
Hoist Contactors Amps	18A	Hoist Contactor Brand	Schneider
Hoist Contactor Model	LC1D25B7C	Hoist Contactor Coil Voltage	24 V
IEC Hoist IP Protection	IP55	Pendant Control Yes No	Yes
IEC Pendant Control Protection	IP66	Pendant Control Emergency Stop	Yes
Pendant Control total Length	17 ft	Hoist Motor Power in KW	3
Hoist Motor Brake Type and DC Voltage	DC170V	Overload Protection	Overload Motor Clutch
Hour Meter	Internal Working Hour Meter	Brake rectifiers-half-wave	PWRX-BKTF-HW
Hoist Motor Insulation Grade	F	Recommended Hoist Protection Circuit Breaker AMPs and Type	Type D 20A
Optional Load Chain Brand & Country of Origin	FEC Japan	Reducer Lubrication Type	Oil
Paint Specifications	Electrostatic Sprayed Plastic (ESP) Epoxy resins, Polyester Resins, Barium, Pigments	Trolley Motor Brake Type and DC Voltage	DC170V
Trolley Motor Insulation Grade	F	Trolley Contactors Amps	32A
Trolley Contactors Brand	Schneider	Trolley Contactors Model	LC1D12B7C
Trolley Contactors Coil Voltage	24 V	Trolley Wheel Diameter	110
Trolley Wheel Material	No. 45 steel	Trolley Minimum Turn Radius	1.5 m / 4.9 ft
Trolley Beam Range	3" to 7"	Trolley Beam Extension Kit	up to 12"
Load Chain weight per foot [lbs]	0.74	1st Package Type	Wood Crate
2nd Package Type	Wood Crate		



Rated load (t)	Type	Dimension (mm)													
		Minimum distance from the bottom of the track to the bottom hook: H	A	L	B	D	E	I	M	N	K	L	T	R	
1	PWRXT1-01	473	440	3500-5500	285	210	20	105	140						
2	PWRXT2-01	516	590		276	368	210	31	24	25	42	32	242	167	
3	PWRXT3-01	600	681		350	422	264	36	28	35	52	42	242	167	
5	PWRXT5-02	645	681		350	478	307	43	30	34	59	48	242	167	

Peso & Dimensiones

Peso Total 407 lbs / 185 Kg

Detalles del Empaque

H Altura Muerta 23.62

A Altura Total 21.26

D Depth 27.36

W Ancho 16.54

J Boca Gancho 2.05

Peso Total (sin cable o cadena) 289.22

Referential Images / Imágenes Referenciales
Specifications may change without notice / las especificaciones pueden cambiar sin previo aviso