

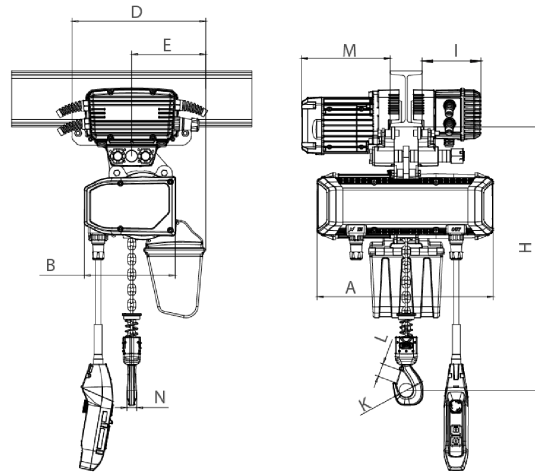

**1/2 ton Electric Chain Hoist w/  
Power Trolley 1 Speed 380V 50HZ**

## Especificaciones Técnicas

<b>Plug</b>	Open Leads	<b>Capacidad de Carga</b>	1/2 ton
<b>Altura de Izaje Estandar (Customizable)</b>	13 ft / 4 m	<b>Velocidad /min</b>	31.49 ft @60Hz 8 mt @50Hz
<b>Numero de Velocidades</b>	1 Speed	<b>Voltaje</b>	3 Phase 380V 50Hz
<b>Clase de Servicio</b>	H4/M5/2m/Class D	<b>Protección IEC Motor</b>	IP55
<b>Control</b>	Pendant Control IP66	<b>Voltaje del Control</b>	48V
<b>Tipo Transmisión / Reductor</b>	Spur gearbox	<b>Tipo de Cadena</b>	G100 Nickel
<b>Dimensiones de la Cadena</b>	6.3mm	<b>Caidas de Cadena</b>	1
<b>Longitud de cadena</b>	13	<b>Humedad</b>	20%~90%
<b>Temperatura</b>	-4 ~ 104° F / -20 ~ 40° C	<b>Potencia del Trolley</b>	500
<b>Velocidad del Trolley /min</b>	43.30 ft @60Hz 11 mt @50Hz	<b>Cantidad de Velocidades</b>	1
<b>Normas</b>	ASME HST-1 , ASME B30.16 , EN60204-37	<b>Garantía</b>	3 Year
<b>Hoist Contactors Amps</b>	10A	<b>Hoist Contactor Brand</b>	Schneider
<b>Hoist UL Components</b>	UL Listed Contactors	<b>Hoist Contactor Model</b>	LC1K09008 / LC2K0910
<b>Hoist Contactor Coil Voltage</b>	48V	<b>IEC Hoist IP Protection</b>	IP55
<b>Pendant Control Yes No</b>	Yes	<b>IEC Pendant Control Protection</b>	IP66
<b>Pendant Control Emergency Stop</b>	Yes	<b>Pendant Control total Length</b>	10 ft
<b>Hoist Motor Power in KW</b>	0.75	<b>Hoist Motor Brake Type and DC Voltage</b>	DC170V
<b>Overload Protection</b>	Overload Motor Clutch	<b>Hour Meter</b>	Internal Working Hour Meter
<b>Brake rectifiers-half-wave</b>	PWRX-BKTF-HW	<b>Hoist Motor Insulation Grade</b>	F
<b>Recommended Hoist Protection Circuit Breaker AMPs and Type</b>	Type D 10A	<b>Optional Load Chain Brand &amp; Country of Origin</b>	FEC Japan
<b>Reducer Lubrication Type</b>	Oil	<b>Paint Specifications</b>	Electrostatic Sprayed Plastic (ESP) Epoxy resins, Polyester Resins, Barium, Pigments
<b>Trolley Motor Brake Type and DC Voltage</b>	DC170V	<b>Trolley Motor Insulation Grade</b>	F
<b>Trolley Contactors Amps</b>	20A	<b>Trolley Contactors Brand</b>	Schneider
<b>Trolley UL Component</b>	UL Listed	<b>Trolley Contactors Model</b>	LC1K09008
<b>Trolley Contactors Coil Voltage</b>	48V	<b>Trolley Wheel Diameter</b>	95
<b>Trolley Wheel Material</b>	No. 45 steel	<b>Trolley Minimum Turn Radius</b>	1.3 m / 4.2 ft
<b>Trolley Beam Range</b>	3" to 5"	<b>Trolley Beam Extension Kit</b>	up to 12"
<b>Load Chain weight per foot [lbs]</b>	0.36	<b>1st Package Type</b>	Wood Crate
<b>2nd Package Type</b>	Wood Crate		



Rated load (t)	Type	Dimension (mm)							
		Minimum distance from the bottom of the track to the bottom hook: H	A	L	B	D	E	I	M
0.25	PWRXT0.25-01	473	440	3500-5500	285	210	20	105	140
0.5	PWRXT0.5-01	473	440		285	210	20	105	140

## Peso & Dimensiones

**Peso Total** 145.2 lbs / 66 Kg

## Detalles del Empaque

**H Altura Muerta** 15.59

**A Altura Total** 15.59

**D Depth** 17.32

**W Ancho** 12.01

**J Boca Gancho** 1.38

**Peso Total (sin cable o cadena)** 116.28

Referential Images / Imágenes Referenciales

Specifications may change without notice / las especificaciones pueden cambiar sin previo aviso