

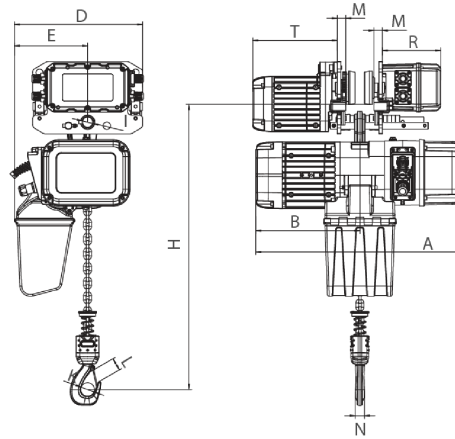

**1 ton Electric Chain Hoist 1 Speed
380V 3ø 50HZ**

Especificaciones Técnicas

Capacidad de Carga	1 ton	Altura de Izaje Estandar (Customizable)	20 ft / 6 m
Velocidad /min	25.59 ft @60Hz 6.50 mt @50Hz	Numero de Velocidades	1 Speed
Voltaje	3 Phase 380V 50Hz	Clase de Servicio	H4/M5/2m/Class D
Protección IEC Motor	IP55	Control	Pendant Control IP66
Voltaje del Control	24V	Tipo Transmisión / Reductor	Spur gearbox
Tipo de Cadena	G100 Nickel	Dimensiones de la Cadena	7.1 mm
Caidas de Cadena	1	Longitud de cadena	20
Humedad	20%~90%	Temperatura	-4 ~ 104° F / -20 ~ 40° C
Normas	ASME HST-1 , ASME B30.16 , EN60204-33	Garantía	3 Year
Hoist Contactors Amps	18A	Hoist Contactor Brand	Schneider
Hoist Contactor Model	LC1D18B7C	Hoist Contactor Coil Voltage	24 V
IEC Hoist IP Protection	IP55	Pendant Control Yes No	Included
IEC Pendant Control Protection	IP66	Pendant Control Emergency Stop	Yes
Pendant Control total Length	17 ft	Hoist Motor Power in KW	1.5
Hoist Motor Brake Type and DC Voltage	DC170V	Overload Protection	Overload Motor Clutch
Hour Meter	Internal Working Hour Meter	Brake rectifiers-half-wave	PWRX-BKTF-HW
Hoist Motor Insulation Grade	F	Recommended Hoist Protection Circuit Breaker AMPs and Type	Type D 4A at 380V
Optional Load Chain Brand & Country of Origin	FEC Japan	Reducer Lubrication Type	Oil
Paint Specifications	Electrostatic Sprayed Plastic (ESP) Epoxy resins, Polyester Resins, Barium, Pigments	Load Chain weight per foot [lbs]	0.58
1st Package Type	Wood Crate		



Rated load (t)	Type	Dimension (mm)													
		Minimum distance from the bottom of the track to the bottom hook: H	A	L	B	D	E	I	M	N	K	L	T	R	
1	PWRXT1-01	473	440	3500-5500	285	210	20	105	140						
2	PWRXT2-01	516	590		276	368	210	31	24	25	42	32	242	167	
3	PWRXT3-01	600	681		350	422	264	36	28	35	52	42	242	167	
5	PWRXT5-02	645	681		350	478	307	43	30	34	59	48	242	167	

Peso & Dimensiones

Peso Total 121 lbs / 55 Kg

Detalles del Empaque

H Altura Muerta 20.31

A Altura Total 17.91

D Depth 23.23

W Ancho 12.99

J Boca Gancho 1.65

Peso Total (sin cable o cadena) 116.44

Referential Images / Imágenes Referenciales
Specifications may change without notice / las especificaciones pueden cambiar sin previo aviso