



## Tecle Cadena Neumatico 16 Tons - 15 metros de izaje - Cadena RUD G80

### Características Esenciales

- 16 Tons Pneumatic Chain Hoist - Heavy Duty - Explosion Proof
- RUD G80 chain made in Germany - 7 meters lifting height (other heights available upon request)
- Includes: Overload Protection - Slip Clutch / Failsafe Automatic Internal Break / Pendant Control with emergency stop (9 meters) / Chain containers
- Meets and exceeds ASME B30.16 / HST-5 standards / Load Test at 130% SWL / ATEX Directive

### Especificaciones Técnicas

<b>Capacidad de Carga</b>	16 Ton	<b>Altura de Izaje Estandard (Customizable)</b>	20 ft / 6 m
<b>Numero de Velocidades</b>	1 Speed	<b>Protección Antiexplosión</b>	- EX 2 GD IIA T4 - EX 2 GD IIB T4 - EXCLUDES Hydrogen Disulphide or Ethelene Oxide - ZONES 1, 2 AND 21, 22
<b>Clase de Servicio</b>	100% Duty Cycle	<b>Freno Motor</b>	>125% WLL Automatic self-adjusting multidisc Brake
<b>Control</b>	Pendant Control w/emergency stop	<b>Tipo Transmisión / Reductor</b>	Epicycle Gearbox (Grease Filled and Sealed)
<b>Tipo de Cadena</b>	G80 RUD Germany 5:1 Safety Factor	<b>Dimensiones de la Cadena</b>	16 x 45 mm
<b>Caidas de Cadena</b>	4	<b>Temperatura</b>	-20°C to 70°C
<b>Nivel de Ruido</b>	84 dBA @ 1m	<b>Normas</b>	ASME B30.11 /B30.16 /HST-5 DIN EN818-7 SANS 1638 compliant ATEX EX Classification according to EC Directive on Hazardous Locations 94/9/EEC
<b>Fabricado en</b>	South Africa	<b>Garantía</b>	3 Year
<b>Pendant Control Yes No</b>	Included	<b>IEC Pendant Control Protection</b>	IP66
<b>Pendant Control Emergency Stop</b>	Yes		

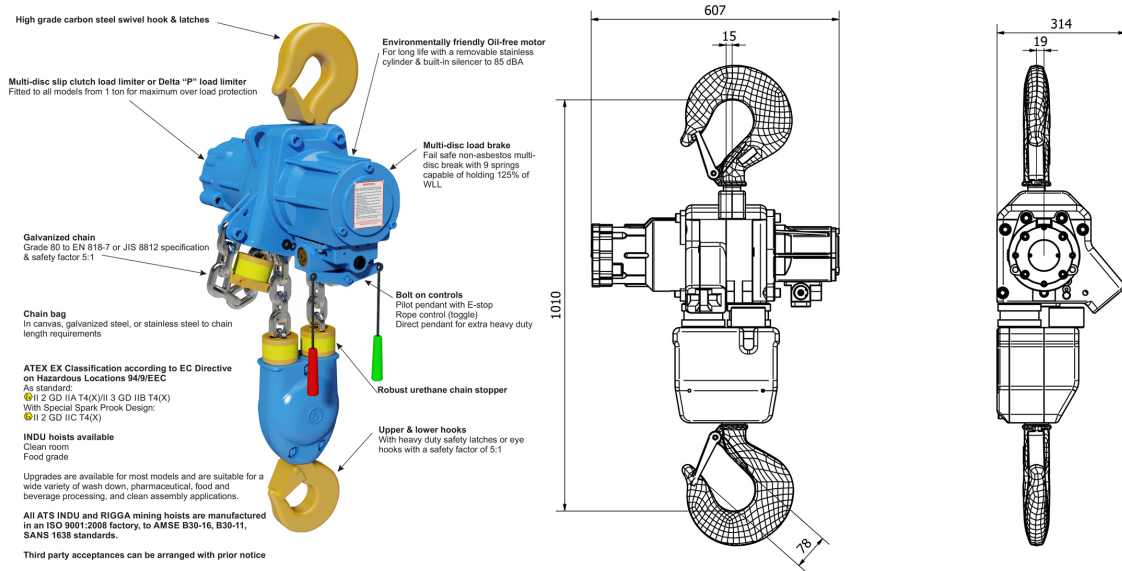

## Detalles del Empaque

H Altura Muerta

39.13

Referential Images / Imágenes Referenciales

Specifications may change without notice / las especificaciones pueden cambiar sin previo aviso