



Tecle Polipasto Prowinch c/carro electrico Monoviga 16 Tons trifasico

Características Esenciales

- Equipo de Doble Velocidad, Mono viga. Servicio Heavy Duty H4/M5.
- Dispositivos de Límite de alta precisión, Protección de Sobrecarga y Protección térmica
- Componentes de alta calidad, Motor SEW Eurodrive, VDF Schneider, contactores Eaton/Schneider
- Estándares US y EC ASME HST-1 , ASME B30.16 , ASME B30.17 , EN14492-2 , EN60204-32.

Especificaciones Técnicas

Capacidad de Carga	35200 lb / 16000 kg	Altura de Izaje Estandar (Customizable)	40 ft / 12 m
Velocidad /min	1.9-13.1 ft / 0.6-4 m	Numero de Velocidades	2 Speed
Voltaje	3 Phase 208~240/480V 50/60Hz	Clase de Servicio	H4/M5/2m/Class D
Tipo de Motor	Squirrel Cage Induction Motor	Freno Motor	Electromagnetic Release Brake >125%
Grado de Aislacion	F	Protección IEC Motor	IP55
Protección Tablero de Control	IP65	Control	Pendant Control and Optional Wireless F21
Voltaje del Control	48V	Marca Motor de Izaje	Sew Eurodrive
Reductor de Izaje	Sew Eurodrive FA	Tipo Transmisión / Reductor	Sew Eurodrive
Humedad	<85%	Temperatura	-4°~104° F / -20°~40° C
Potencia del Trolley	0.75*2 kW	Nivel de Ruido	82 dB
Velocidad del Trolley /min	16 ~ 65 ft/min. / 5 ~ 20 m/min	Normas	ASME HST-4 , ASME B30.16 , B30.17 , EN14492-2 , EN60204-32
Garantía	3 Year	Hoist Contactor Brand	Schneider or EATON

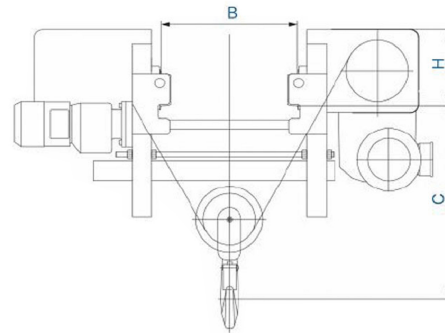
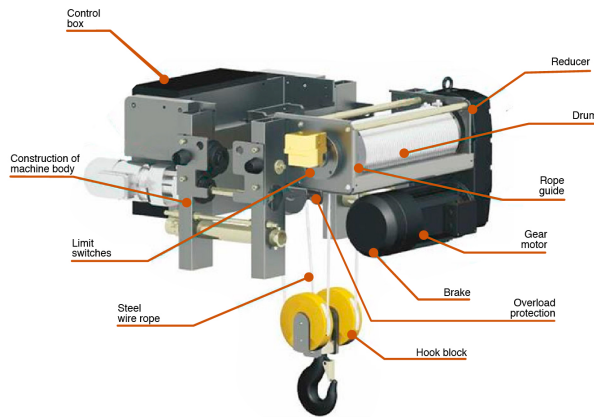

DRIVE TECHNOLOGY

SEW Eurodrive high performance Motor, reducer and brake. Compact design, light weight, low energy consumption, low noise and eco-friendly design. Electromagnetic brake disc (Asbestos-free). Long Service life and easy maintenance.



OVERLOAD PROTECTION

Load Cell connected to a Limit Relay (Adjustable) to avoid overloading of the hoist.



WIRE ROPE GUIDE

Helps the winding of the rope on the drum. Light weight and highly resistance. Design to reduce friction on the wire rope and avoid premature wear.

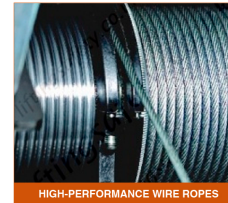

HIGH-PERFORMANCE WIRE ROPES

High-performance wire rope with tensile strength up to 2160Mpa. Galvanized surface and high flexibility to ensure long service life.



DRUM

Q345 steel, seamless grooved drum. Design to fulfill FEM and ASME standards and ensure a safe operation.



LIMIT SWITCHES

High precision adjustable height limit switches, for all movements of hoist and trolley.

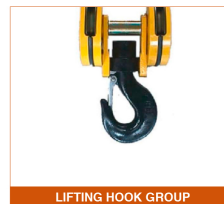

LIFTING HOOK GROUP

DIN standard lifting hook with safety clasp. Forged by the high-strength material of T grade.



CONTROL BOX

Electric Control box with Schneider Inverter, Eaton contactors and components. Compact design, easy access, IP65 Enclosure.

Detalles del Empaque

H Altura Muerta

36.22

A Altura Total

51.97

Referential Images / Imágenes Referenciales
Specifications may change without notice / las especificaciones pueden cambiar sin previo aviso