

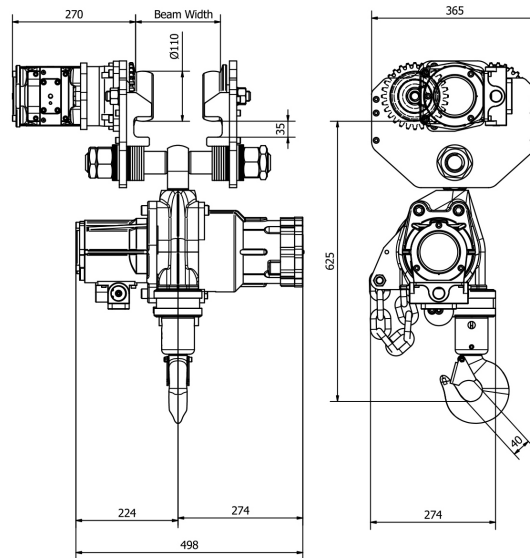

5 Tons Air Chain Hoist with Trolley 9 meters lifting - ATEX Explosion Proof

Especificaciones Técnicas

Capacidad de Carga	5 Ton	Altura de Izaje Estandar (Customizable)	30 ft / 9 m
Numero de Velocidades	1 Speed	Protección Antiexplosión	EX 2 GD IIA T4 EX 2 GD IIB T4 EX 2 GD IIC T4 ZONES 1, 2 AND 21, 22 - Copper Coated: Chain hook, bottom block, Sprocket, Load sleeve, Safety Catch - Stainless Steel Wheels
Clase de Servicio	100% Duty Cycle	Freno Motor	>125% WLL Automatic self-adjusting multidisc Brake
Control	Pendant Control 4 buttons w/emergency stop	Tipo Transmisión / Reductor	Epicycle Gearbox (Grease Filled and Seald)
Tipo de Cadena	G80 RUD Germany 5:1 Safety Factor	Dimensiones de la Cadena	16 x 45 mm
Caidas de Cadena	1	Longitud de cadena	9 m
Potencia del Trolley	0.3 kW	Nivel de Ruido	84 dBA @ 1m
Velocidad del Trolley /min	10 m/min	Cantidad de Velocidades	1
Rango de ancho de la Viga	112 - 212 mm	Radio Mínimo de Giro	1.8 m
Normas	ASME B30.11 / B30.16 / B30.17 / HST-5 DIN EN818-7 SANS 1638 compliant ATEX EX Classification according to EC Directive on Hazardous Locations 94/9/EEC	Fabricado en	Southafrica
Garantía	3 Year		



Detalles del Empaque

H Altura Muerta	24.61
D Depth	10.79
W Ancho	19.61
J Boca Gancho	1.57

Referential Images / Imágenes Referenciales
 Specifications may change without notice / las especificaciones pueden cambiar sin previo aviso