



Tecle Cadena con Carro Electrico 10 tons 3 Fases 12 Metros 1 speed Heavy Duty

Características Esenciales

- La Calidad está adentro: Heavy Duty H3/M4. Aluminum Alloy housing, NSK Bearings, USA Chevron Meropa
- Componentes eléctricos Eaton y Schneider, Limitadores de Recorrido en todas las direcciones
- Cadena G100 Super Heavy Duty, 25% superior a la G80. Standard ASTM A973
- Estándares US y EC ASME HST-1 , ASME B30.16 , EN14492-2 , EN60204-32

Especificaciones Técnicas

Plug	Open Leads	Capacidad de Carga	22000 lb / 10000 kg
Altura de Izaje Estandar (Customizable)	40 ft / 12 m	Velocidad /min	9ft/2.7m@60Hz 7.5ft/2.3m@50Hz
Numero de Velocidades	1 Speed	Voltaje	3 Phase 208~240/480V 50/60Hz
Clase de Servicio	H3/M4/1Am/Class C	Freno Motor	Yes
Protección IEC Motor	IP55	Control	Pendant Control and Optional Wireless
Voltaje del Control	24V	Tipo Transmisión / Reductor	Spur gearbox with Oil splash lubrication
Tipo de Cadena	G100	Dimensiones de la Cadena	11.2 x 34
Caidas de Cadena	4	Longitud de cadena	160 ft / 48.5 m
Humedad	<85%	Temperatura	-4 ~ 104° F / -20 ~ 40° C
Potencia del Trolley	0.8 kW x 2	Nivel de Ruido	81 dB
Velocidad del Trolley /min	36 ft / 11 m	Cantidad de Velocidades	1
Rango de ancho de la Viga	100-178 mm	Radio Mínimo de Giro	6.6 ft / 2 m
Normas	ASME HST-1 , ASME B30.16 , B30.17 , EN60204-32	Garantía	3 Year
T Motor del Carro	9.09 in / 231 mm	R Carro Ancho Caja	5.5 in / 142 mm
Hoist Contactor Brand	EATON 25 AMP		

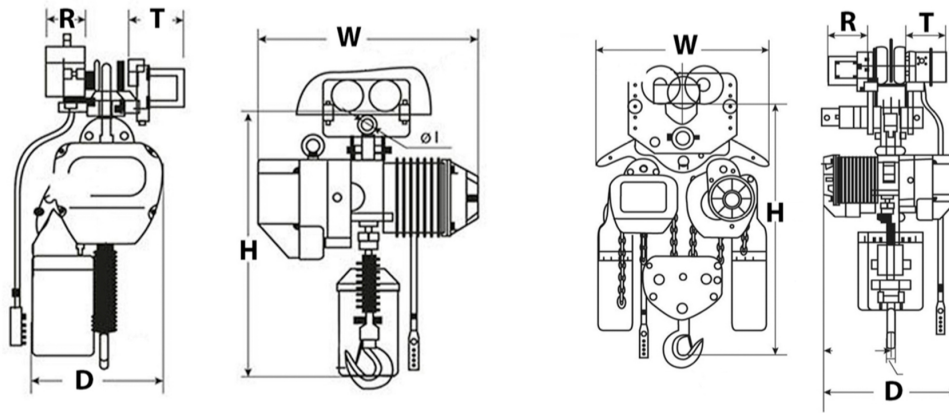

		Model	PWRC1	PWRC2	PWRC3	PWRC5	PWRC7	PWRC10	PWRC20
		Dimensions	T	9.09	9.09	9.09	9.09	9.09	9.09
H	25.5		30.5	33	40	48	55	58	
W	20.5		24.5	24	24	24	25	25	
R	5.5		5.5	5.5	5.5	5.5	5.5	5.5	
D	12		17	17	17	20	35	50	



Peso & Dimensiones

Detalles del Empaque

Peso Total	900 lbs / 409 Kg	H Altura Muerta	46.85
		D Depth	14.96
		W Ancho	24.8
		J Boca Gancho	3.66

Referential Images / Imágenes Referenciales
Specifications may change without notice / las especificaciones pueden cambiar sin previo aviso