

**1/2 Ton 2 Speed Power Trolley
380V 60HZ with Limit Switches
Pendant not Included**

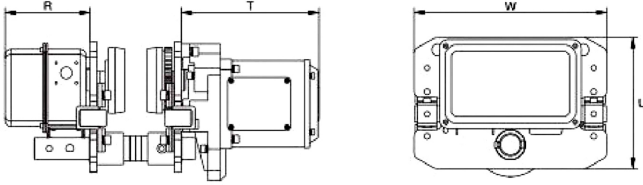

Especificaciones Técnicas

Capacidad de Carga	1100 lb / 500 kg	Voltaje	3 Phase 380V 50Hz
Velocidad del Trolley /min	36 - 68 ft /11 - 21 m	Rango de ancho de la Viga	52 - 153 mm
Radio Minimo de Giro	2.6 ft / 0.8 m	Garantía	3 Year
T Motor del Carro	5.6 in / 142 mm	R Carro Ancho Caja	9 in / 231 mm



Model / Modelo	PWQE1Ti	PWQE2Ti	PWQE3Ti	PWQE5Ti	PWQE7Ti	PWQE10Ti
W	12.4 in / 315mm	12.7 / 325mm	13.3in / 340mm	15.7 in/ 400mm	26.5 in / 670 mm	19.6in / 500mm
U	8.3 in / 212mm	8.6mm / 220mm	9.8 in / 250mm	11.4 in / 291mm	-	14.6in / 371mm
R	5.5 in / 142mm	5.5 in / 142mm	5.5 in / 142mm	5.5 in / 142mm	9 in / 231 mm	5.5 in / 142mm
T	9 in / 231mm	9 in / 231mm	9 in / 231mm	9 in / 231mm	5.6 in / 142 mm	9 in / 231mm

Peso & Dimensiones

Detalles del Empaque

Peso Total	92.4 lbs / 42 Kg	D Depth	11.34
		W Ancho	21.46

Referential Images / Imágenes Referenciales

Specifications may change without notice / las especificaciones pueden cambiar sin previo aviso