

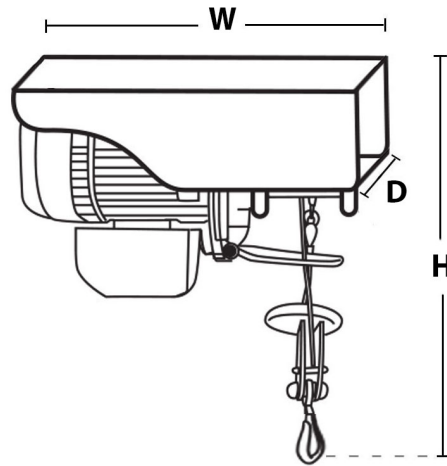

**440 lb 220V Electric Wire Rope  
 Hoist 38 ft. H1 Duty Wireless.  
 Wireless Upper Limit Switch 3th  
 Generation H1 Duty**

**Especificaciones Técnicas**

<b>Capacidad de Carga</b>	200Kg @ 2 lines   100Kg @ 1 line	<b>Altura de Izaje Estandard (Customizable)</b>	40ft single line / 20ft double line (12m / 6m)
<b>Velocidad /min</b>	33 ft/10m @1line   16ft/5m @2line	<b>Numero de Velocidades</b>	1 Speed
<b>Voltaje</b>	1 Phase 220~240V 50/60Hz	<b>Clase de Servicio</b>	H1/M2/1Cm/Class A
<b>Tipo de Motor</b>	Squirrel Cage Induction Motor	<b>Potencia Motor</b>	450W
<b>Freno Motor</b>	YES	<b>Grado de Aislacion</b>	B
<b>Protección IEC Motor</b>	IP54	<b>Control</b>	Wireless F21 Remote Control
<b>Voltaje del Control</b>	2 x AA 1,5v	<b>Cable</b>	ø1/8 in / ø3.0 mm
<b>Humedad</b>	<85%	<b>Temperatura</b>	-4°~104° F / -20°~40° C
<b>Nivel de Ruido</b>	71 dB	<b>Normas</b>	ASME B30.16
<b>Garantía</b>	1 Year	<b>Standards Certified</b>	Intertek 4006091 , CAN/CSA C22.2 , EN14492-2 , EN60204-32



## Peso & Dimensiones

**Peso Total** 21 lbs / 10 Kg

## Detalles del Empaque

**H Altura Muerta** 12.13

**D Depth** 5.75

**W Ancho** 14.37

Referential Images / Imágenes Referenciales  
Specifications may change without notice / las especificaciones pueden cambiar sin previo aviso